

HANDLING AND ASSEMBLY INSTRUCTIONS FOR TRUE FOCUS 3.0M, 3.8M AND 4.2M ANTENNAS WITH POLAR MOUNT

SECTION 1

Introduction

Thank you for purchasing one of our fine True Focus products. This manual covers the installation and assembly of the 3.0M, 3.8M, and 4.2M Polar Mount. Andersen Manufacturing, Inc. disclaims all responsibility for the improper installation of our mounts and antennas. Make sure that installation meets all codes and ordinances for your area.

General Description

The Polar Mount allows an antenna to track the Clark Belt with outstanding accuracy. Fine Tune Elevation and declination adjustments allow accurate settings. Motorized or hand crank jack arms can be used with this mount. It may be installed on any adequately anchored and secured 6" Schedule 40 pipe. See attached sheet for recommended foundations.

SECTION 2

UNPACKING AND INSPECTION

Unpack and inspect the antenna and mount for damage or missing parts. Check against the parts list enclosed. Occasionally material may be damaged in transit. If this occurs, contact the freight company for damaged freight procedures. If any parts are missing or damaged, not due to shipping, contact our Customer Service Department:

**ANDERSEN MANUFACTURING, INC.
3125 N. YELLOWSTONE HWY.
IDAHO FALLS, IDAHO 83401
PHONE: (208) 523-6460
FAX: (208) 523-6562
WATTS: (800) 635-6106**

SECTION 3

SITE AND INSTALLATION GUIDELINES

The following guidelines must be adhered to:

1. The line of sight for the antenna must be clear of obstructions such as trees and buildings.
2. The mounting pole should be sufficiently anchored to prevent the wind from toppling the antenna. Refer to the attached sheet for recommended foundations.
3. Follow all local building codes, grounding, foundation requirements, zoning rules etc.

SECTION 4 INSTALLATION

In all handling of the antenna sections, it is imperative that adequate support is given to prevent damage. This should be done by lifting and carrying the antenna sections at the job site with 3 people. Hold the antenna in the vertical position as they come in the shipping crate.

See Fig. #1

FIGURE #1

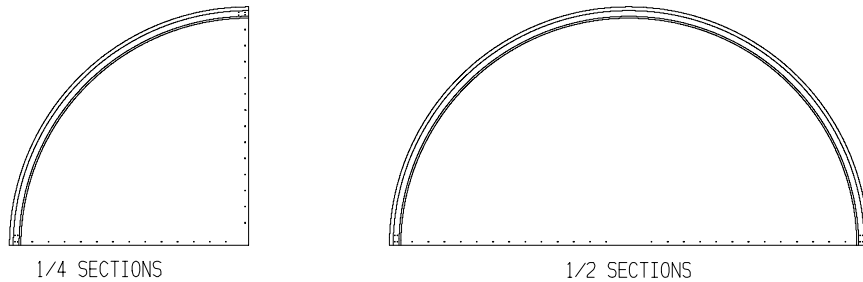

STEP 1.

To prevent damage when laying the sections down for assembly, four people are required to support the half sections and three people are required for handling quarter sections. See Fig. #2.

FIGURE #2

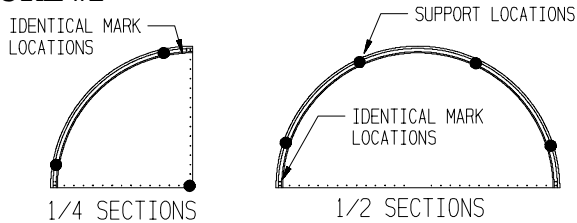
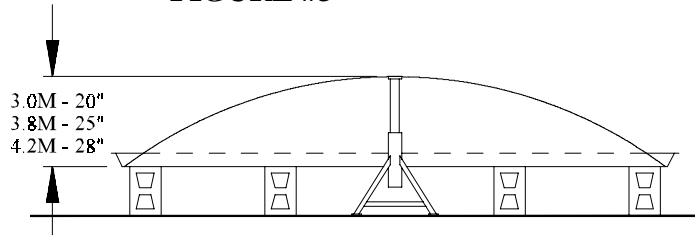

FIGURE #3



STEP 2.

As each half or section is laid down, place block or adjustable jacks around the rim of the antenna for support.

NOTE: IF RECEIVING MORE THAN ONE ANTENNA ASSEMBLY OR A 4 PIECE ANTENNA ASSEMBLY IN A SHIPPING CONTAINER, THE CORRECT HALVES OR SECTIONS MUST BE MATCHED UP AS DESCRIBED BELOW:

HALVES: An identical mark has been stamped in the flat of the antenna rim. These marks must be matched up when halves are assembled.

QUARTER SECTIONS: As the installer is facing the back of the antenna, identical marks are stamped in the flat of the antenna rims. These indicate which antenna the sections belong to. At the point of the section, or what will be the center of the antenna, each section has been labeled 1 thru 4. These are assembled in a **CLOCKWISE** direction.

Match the correct sections as indicated when the antenna is laid down on the blocks. The blocks or jacks should hold the antenna high enough for a person to crawl under the rim. The blocks should be level to prevent uneven stresses in the antenna during assembly. ***IMPORTANT*** When placing the antenna onto the blocks, you must rest each section on the center support jack. This supports the center of the antenna at the heights above the rim as shown in Fig. #3.

STEP 3.

Bolt the 2 1/2" X 8" stainless steel rim support strap to the inside of the rim flange with the 1/4" X 1/2" stainless steel hex head bolts. See Fig. #4.

FIGURE #4

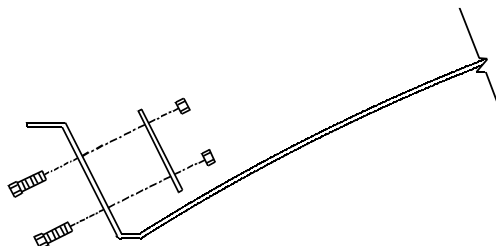

STEP 4

Lay the 2 1/2" wide stainless steel back strap over the joint on the back of the antenna. Line up the holes and begin bolting (finger tight) up the joint from the edge, working toward the center of the antenna from both sides. When you are as far toward the center of the antenna as you can reach, the smallest installer (under 200 lbs. and wearing soft soled shoes) can climb onto the antenna to finish bolting the back strap. Make certain that lock washers have been used on all bolts. Once all bolts are in place begin tightening with a wrench. Make certain that the antenna

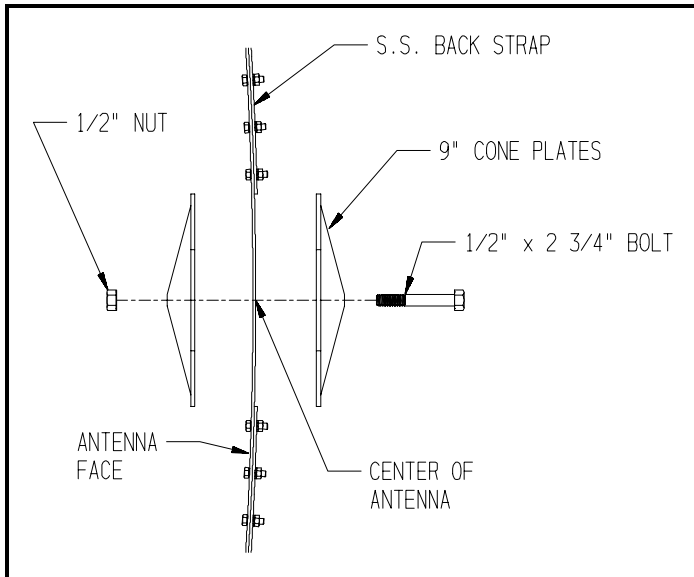

Figure #4a

section joints maintain an even .075" [1.905 mm] gap all the way across the antenna face. Square shims have been provided in the bolt package with the antenna face screws, to use as gauges to set the proper gap. Place the shims in the gap between the antenna sections and push the sections together until the shim is compressed tightly between them. Tighten the fasteners, then remove the shims. Place the 9" cone plates on either side of the antenna center, one on the inside of the reflector, and one on the back, as shown in Fig #4a. Insert the 1/2" x 2 3/4" bolt through the back plate, the antenna, and the front plate. Place a 1/2" nut on the bolt and tighten securely. (Note: One installer must be under the antenna to hold a wrench during this step.)

Step 5

After the antenna has been assembled, following the above instructions, place the antenna face down on six blocks equally spaced around the antenna rim. Ensure

that the antenna is high enough off the ground so a worker can crawl under the antenna and place bolts through the face of the antenna during assembly. Using shims, level the antenna so it is resting equally on all six points.

Step 6

Assemble the hat ring as shown in Fig #5, pay careful attention to the locations of each piece on the ring assembly.

The square tube section with the two 1/2" dia. holes in it, goes in the bottom of the ring, while the section with the two 3/4" holes in it goes in the top of the hat ring assembly. Also orient the two sections with the single 3/4" hole in them as shown in the illustration. Use the 7/16" x 1" bolts and nuts to bolt the sections together. Only tighten the sections together finger tight at this time. Insert the actuator tab into the hat ring in one of the 3/4" holes as shown and tighten it down with a 3/4" lock nut. **NOTE: As a rule, if you are East of the Mississippi River in the Continental U.S., the actuator tab is attached to the LEFT side of the hat ring (as shown). West of the Mississippi, the tab is attached to the RIGHT side of the hat ring.**

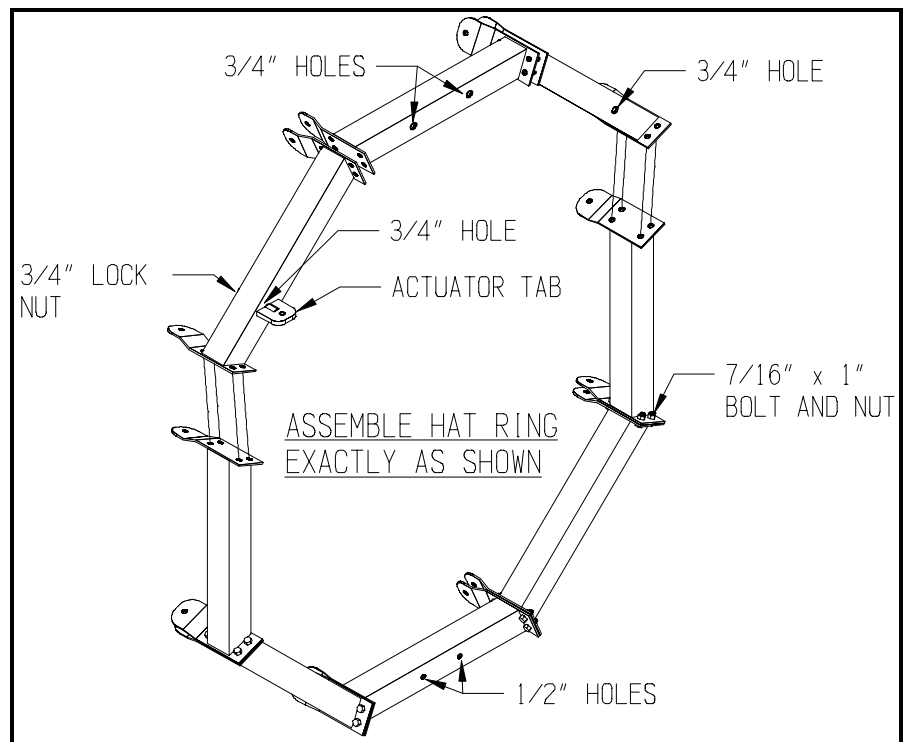

Figure #5

Step 7

After the hat ring has been assembled, bolt the rocker arms to the hat ring as shown in Fig. #6. Note that the longer end of the rocker arm is oriented toward the outside of the hat ring. Use the 1/2" x 2 1/4" bolts provided, and tighten the nuts finger tight only.

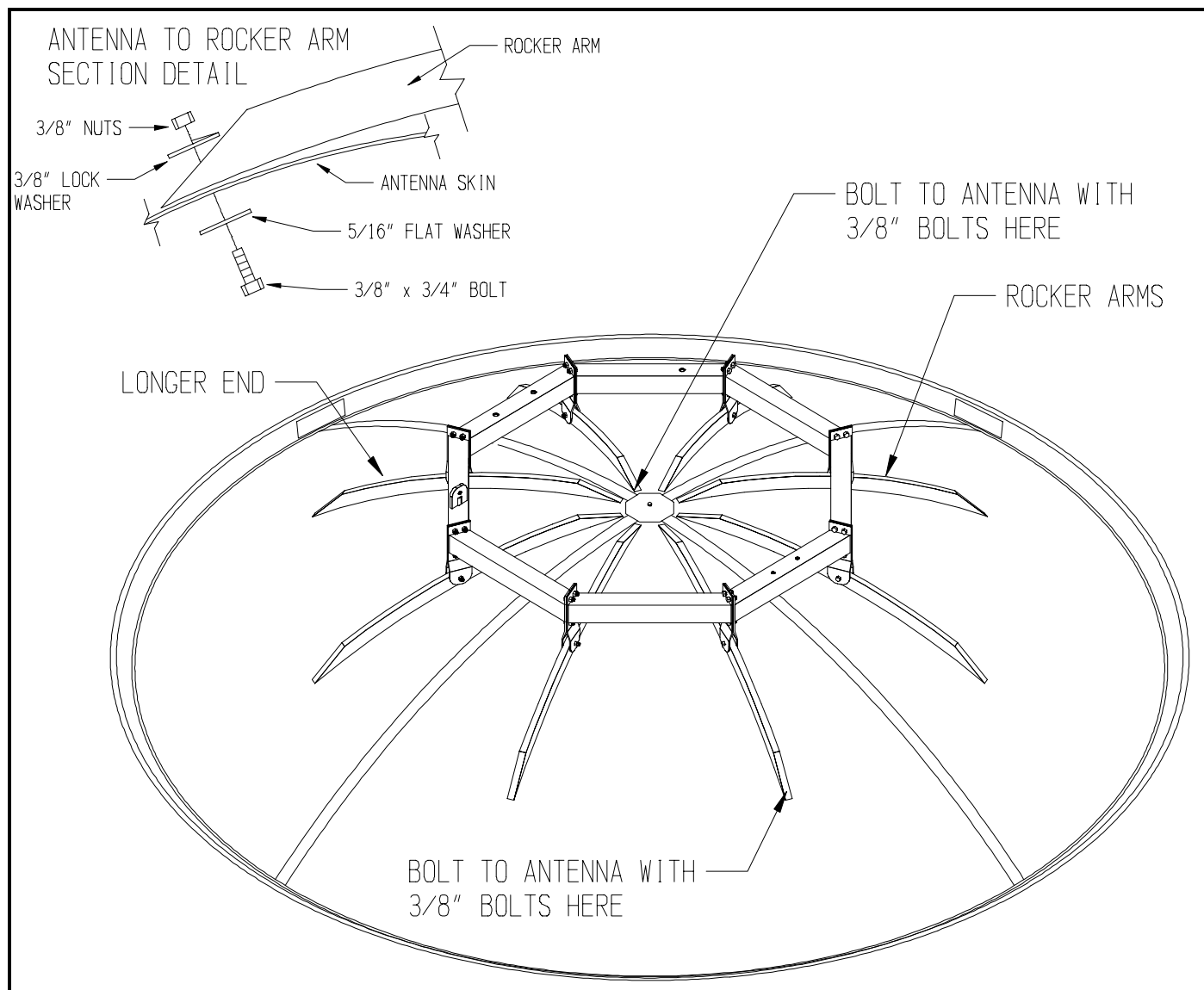

Figure #6

Step 8

Using a crane or forklift to raise the hat ring, set it on the antenna, rotating and positioning it, so the bolt holes in the back of the antenna line up with the holes in the rocker arms. If the rocker arms have not been installed correctly on the hat ring, the holes will not line up. Orient the bottom of the hat ring so one of the antenna seams appears to run in between the bottom two bolt holes, perpendicular to the bottom section, and the other seam is parallel to the bottom section. This will orient the seams in the final assembly, horizontal and vertical. With one person under the antenna and one on top, insert the 3/8" x 3/4" bolts with 5/16" flat washers on them, through the face of the antenna, and then through the rocker arms on the back of the antenna. Next place a 3/8" lock washer on the bolt and a 3/8" hex nut. Tighten these 3/8" bolts securely at this time. Now tighten the 7/16" bolts of the hat ring securely and evenly. Finally, tighten down securely the 1/2" bolts in the rocker arms.

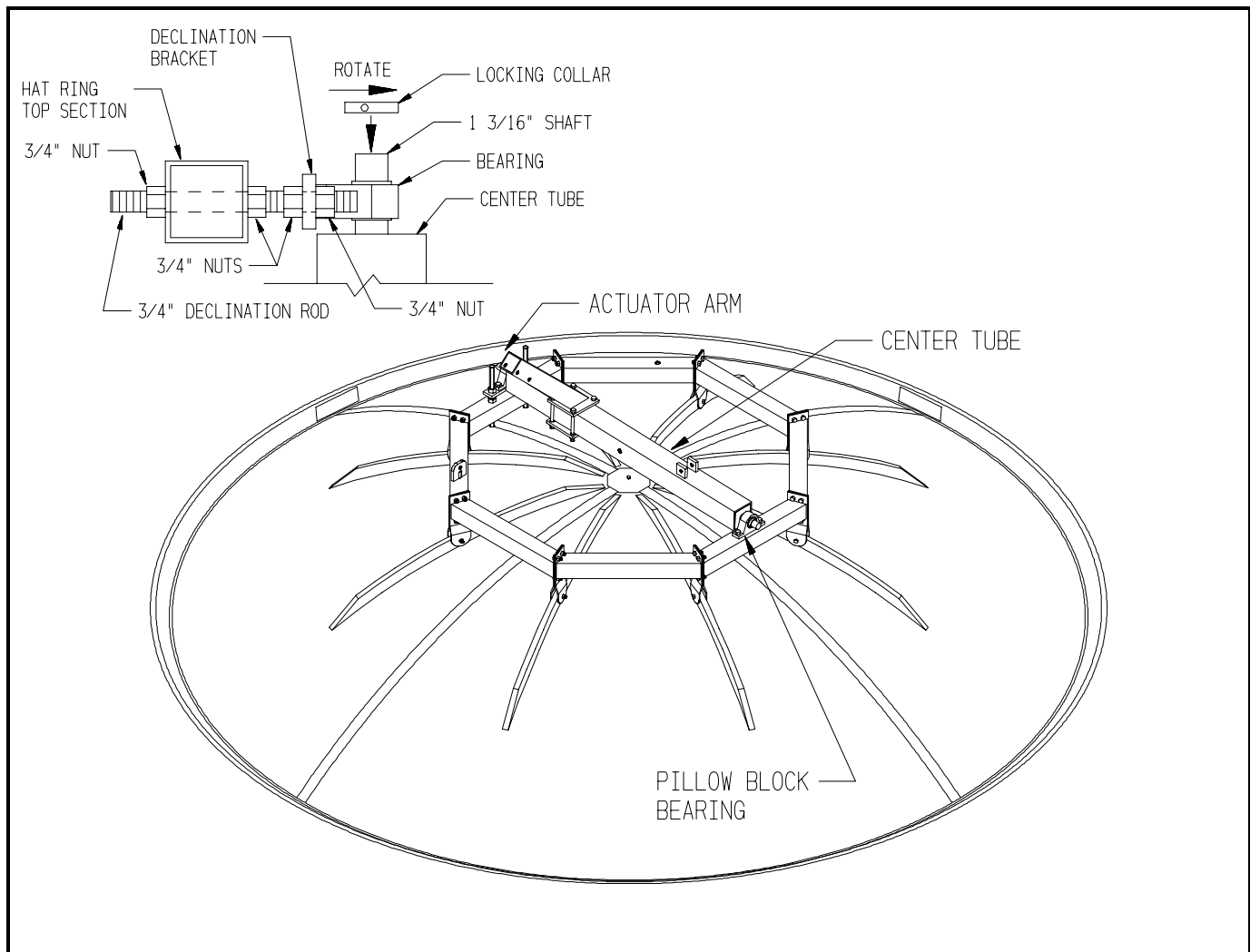

Figure #7

Step 9

Locate the two pillow block bearings, and place each one on the 1 3/16" shafts at each end of the center tube. Place the locking collar on the end of the shaft after the bearing and tighten the set screw, but do not lock into place on the bearings at this time. For reference, the two tabs on the center tube are on the bottom end. Fasten the declination bracket to the top bearing block by 1/2" X 2 1/4" bolts with 7/16" flat washers on them and nuts. Tighten bolts securely. Attach the declination adjustment rods to the declination bracket as shown with the 3/4" nuts. Place another 3/4" nut on each declination rod, and thread on all the way against the other 3/4" nuts. Now attach the jack arm bracket as shown in Fig. #7 with the four 5/8" X 6" bolts and the 6" square sandwich plate to the center tube. Place 5/8" nuts on the bolts and tighten securely. The jack arm has been made adjustable to raise and down to prevent binding of the actuator arm, and reversible for geographic location. **Note: the actuator tab needs to be on the same side as the actuator arm as shown in the illustration. Refer to the Note at the end of Step 6.** Adjust as needed.

Step 10

Lift the center tube assembly onto the back of the hat ring assembly, and attach as shown in Fig. #7. Insert 1/2" X 4 1/2" bolts with 7/16" flat washers on them through the bottom bearing and into the bottom section of the hat ring. Tighten 1/2" nuts securely on them. Slide the 3/4" declination rods through the top hat ring section, and place 3/4" nuts on each rod, tightening them securely. Center the center tube between the two bearings. Now loosen the locking collar on the bottom bearing and slide it tight against the bearing.

Rotate the collar with a center punch in the hole provided, 1/4 of a turn which will secure the shaft to the bearing. Do not set the locking collar of the top bearing until after the declination is set, to prevent binding the hat ring. Tighten the set screws on the lock collars, after they are secured, setting them to the shafts.

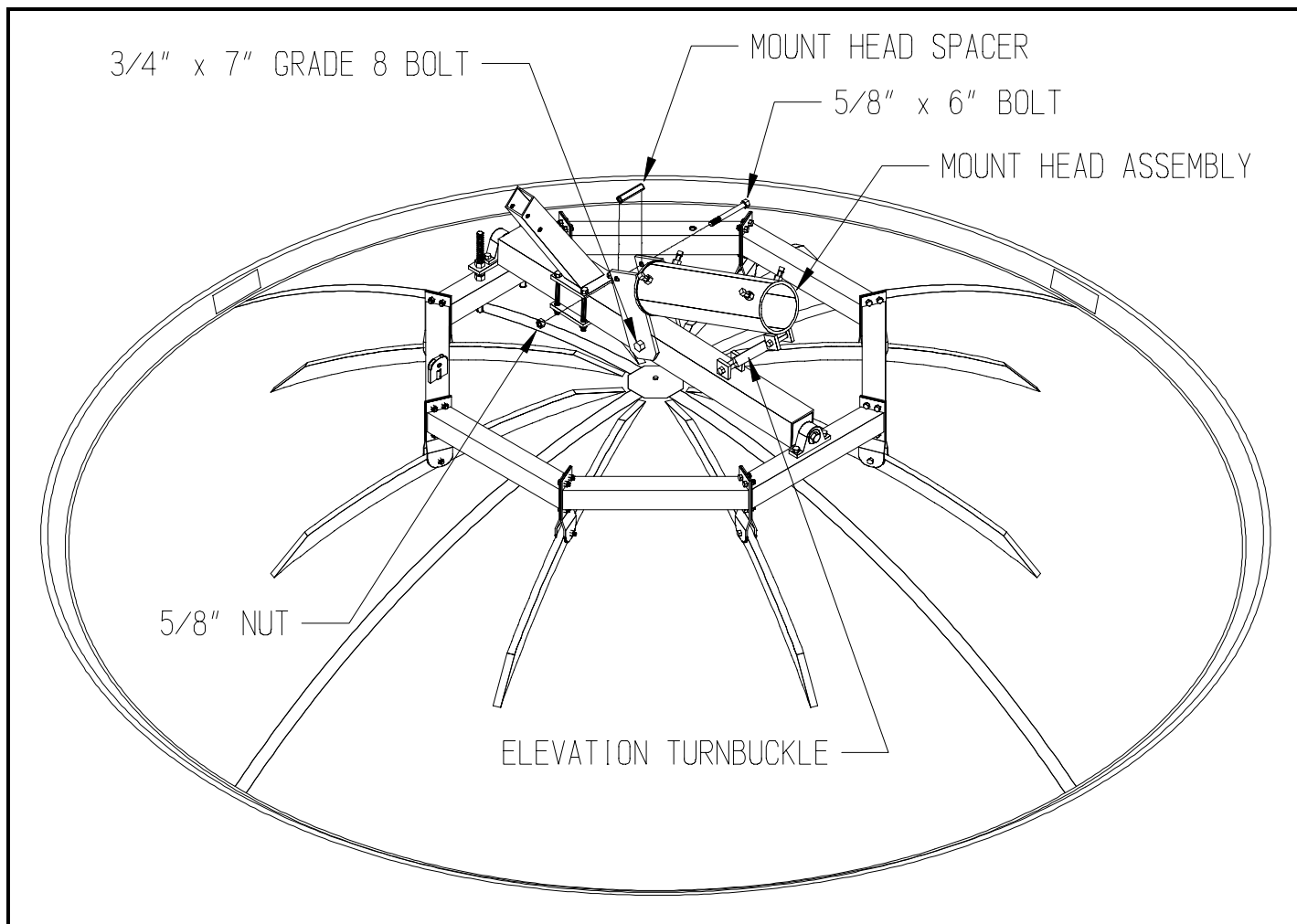

Figure #8

Step 11

Attach the mount head assembly to the center tube as shown in Fig. #8, with the 3/4" x 7" grade 8 bolt and 3/4" lock nut. Install the elevation turn buckle as shown in Fig. #8, with the 3/4" x 4" bolts, tightening them securely. Also install the mount head spacer at this time. Do not tighten the 5/8" X 6" bolt for the mount head spacer until after the final elevation has been set. Before lifting the antenna and mount assembly onto the pole, double check that all bolts have been tightened securely, to prevent a possible warping of the antenna during this step. Lift the antenna by the hat ring assembly to a vertical position and set it on a pre-anchored 6" Schedule 40 pipe. Use caution so the antenna is not damaged by colliding with anything.

Step 12

Orient the mount head so it is facing due South on a North/South axis. Tighten the set screws in the mount head to secure it to the post. An Actuator Adapter plate has been included with the bolt package for the mount. The Adapter may or may not be needed depending upon your Geographical Location. Use the actuator adapter only if you are unable to achieve a full swing to the East or West. Attach the adapter to the end of the actuator arm on the back of the mount as shown in Fig. #9 with two 1/2" x 4 1/2" bolts and 1/2" lock nuts. Install the linear actuator jack so it rests above or on top of the actuator arm. Adjust the actuator arm up or down as needed to prevent the linear actuator jack from binding. Set the elevation as required, using the center tube as a reference location for

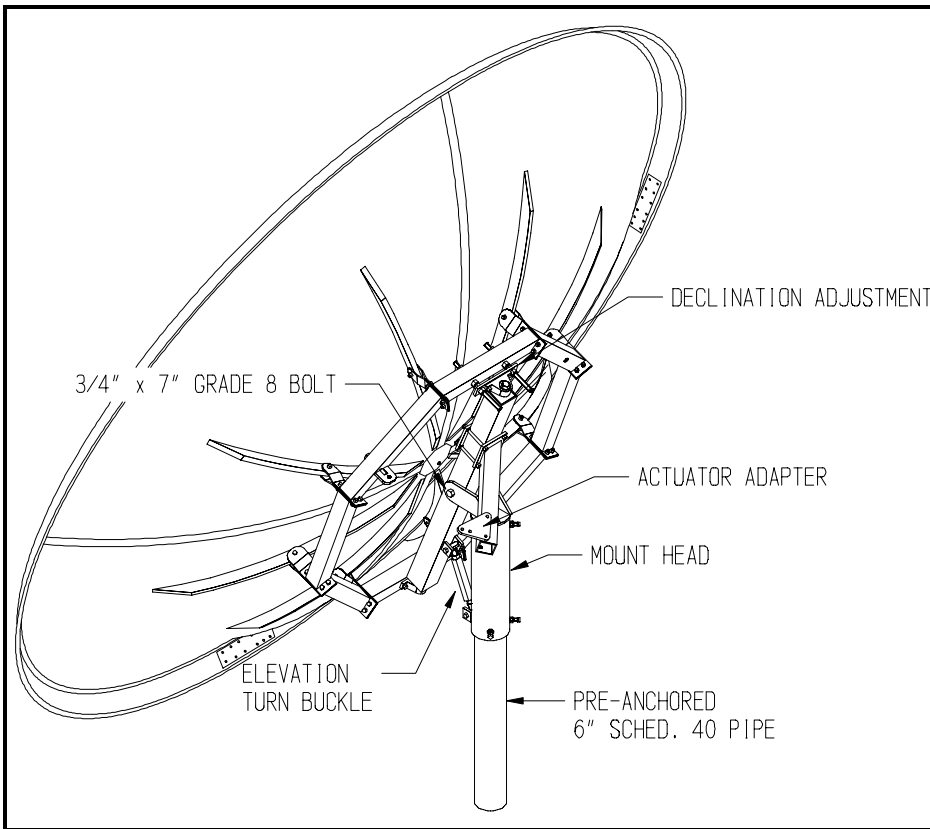

Figure #9

your inclinometer. Also set the declination at this time, allowing for the built in 1.5 degrees of declination in the mount. If less than 1.5 degrees declination is needed, a plate will be provided to go between the lower bearing and the hat ring. Now tighten down the 5/8" mount head spacer bolt securely.

STEP 13.

Place the four feed support rods and feed horn onto the antenna as shown in Fig. #10, and polarize as needed. In order to ease installation, it is recommended first that the four feed support rods be attached to the scalar ring of the feed. Taking care not to bend the feed support rods, use one person to suspend the feed assembly near the proper location out from the center of the antenna, while another attaches the feed supports to the rim of the antenna.

FOCAL LENGTHS: 3.0M - 45" 3.8M - 56.25" 4.2M - 63"

Figure #10

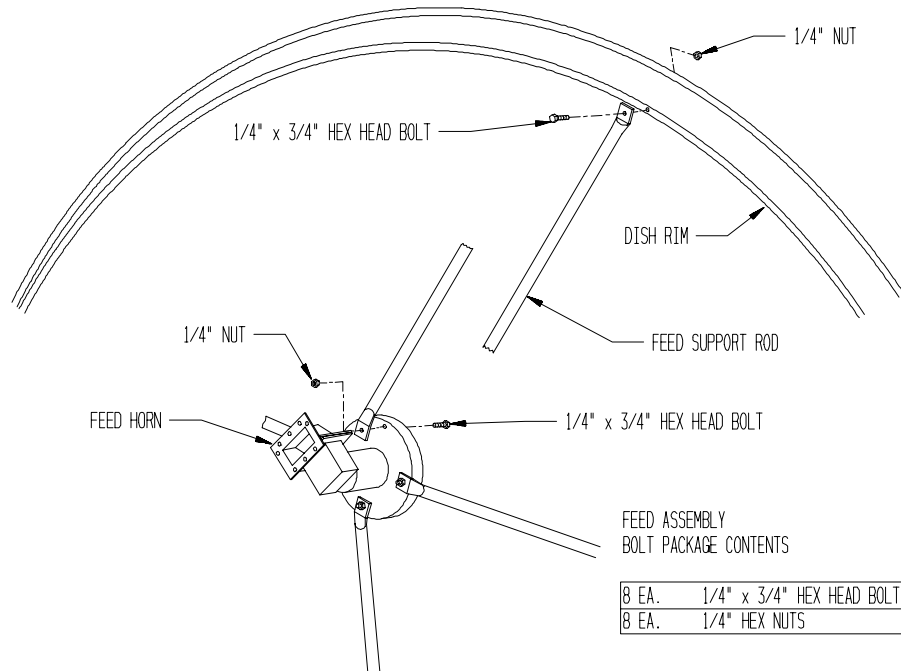

STEP 14.

After the antenna has been fine tuned to the satellite, make certain that all bolts and nuts are tight. Periodic inspection is recommended to help maintain optimum performance.

8 EA.	1/4" x 3/4" HEX HEAD BOLTS
8 EA.	1/4" HEX NUTS

PARTS LIST

MOUNT PARTS

<u>QTY.</u>	<u>DESCRIPTION</u>	<u>QTY.</u>	<u>DESCRIPTION</u>
8	HAT RING SECTIONS	8	ROCKER ARMS
1	CENTER TUBE	2	PILLOW BLOCK BEARINGS
1	TURN BUCKLE ASSEMBLY	1	ACTUATOR ARM
1	MOUNT HEAD ASSEMBLY	1	ACTUATOR TAB
1	DECLINATION BRACKET	1	6" SQ. SANDWICH PLATE
1	MOUNT HEAD SPACER TUBE	2	9" CONE PLATES
1	ACTUATOR ADAPTER PLATE		

MOUNT BOLT PACKAGE

<u>QTY.</u>	<u>DESCRIPTION</u>	<u>QTY.</u>	<u>DESCRIPTION</u>
16	3/8" x 3/4" BOLTS	16	3/8" NUTS
16	5/16" FLAT WASHERS	16	3/8" LOCK WASHERS
32	7/16" x 1" BOLTS	32	7/16" NUTS
8	1/2" x 2 1/4" BOLTS	9	1/2" NUTS
6	1/2" LOCK NUTS	4	1/2" x 4 1/2" BOLTS
4	7/16" FLAT WASHERS	5	5/8" x 6 BOLTS
5	5/8" LOCK NUTS	2	3/4" x 4" BOLTS
1	3/4" x 7" BOLT	2	3/4" LOCK NUT
10	3/4" NUTS	2	1/2" x 2" BOLTS
1	1/2" x 2 3/4" BOLT		

ANTENNA BOLT PACKAGE

Four Piece Antenna Assembly Back Strap Bolt Package

	10' (3.0M)	12.5' (3.8M)	14' (4.2M)	EXTRA
1/4" x 5/8" S.S. FLAT HEAD SCREWS	80	96	112	4
1/4" x 5/8" S.S. HEX HEAD CAP SCREWS	32	32	32	1
1/4" S.S. HEX NUTS	112	128	144	4
1/4" S.S. LOCK WASHERS	112	128	144	4
.075" SHIM STOCK FOR ANTENNA GAP ADJUSTMENT	16	16	16	